

### THREAD TAKE UP LEVER, NEEDLE BAR, MAIN SHAFT

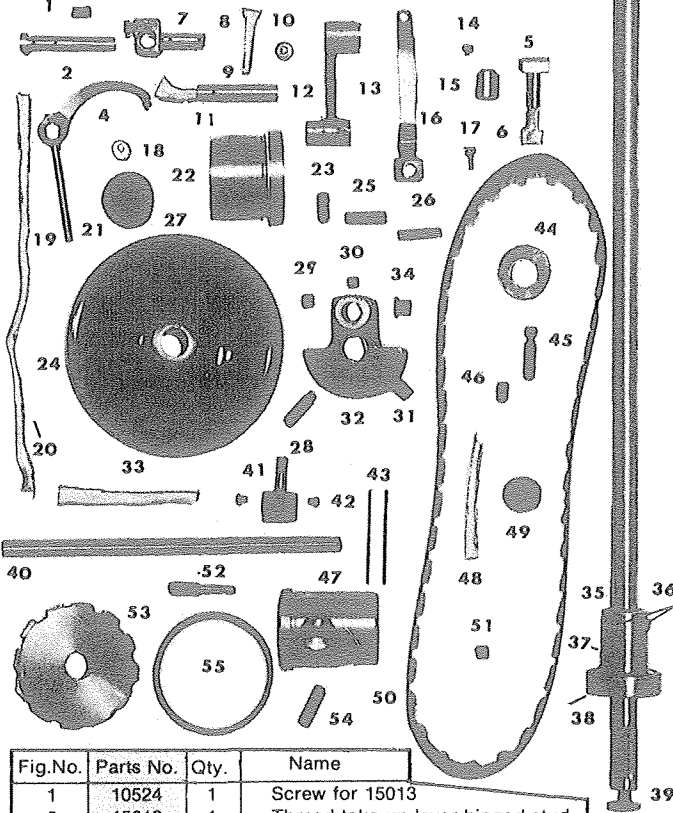

Fig.No.	Parts No.	Qty.	Name
1	10524	1	Screw for 15013
2	15013	1	Thread take up lever hinged stud
3	11042	1	Oiling wick for 15013
4	11039	1	Thread take up lever
5	10529	1	Take up lever driving stud
6	10728	1	Oiling wick for 10529
7	10532	1	Screw for 10856
8	10856	1	Needle bar connecting stud
9	10726	1	Oiling wick for 10856

10	15038	1	Oil stop screw for 10523
11	10726	1	Oiling wick for 10523
12	10523	1	Needle bar connecting link stud
13	10528	1	Needle bar connecting link
14	10597	1	Screw for 11004
15	11004	1	Oil regulator
16	15086	1	Oil regulator spring
17	8040	1	Screw for 15086
18	11142	1	Washer for 8040
19	11012	1	Oil reservoir oil wick
20	15034	1	Oil regulator vinyl pipe
21	11024	2	Felt for 10562 (large)
22	13074	1	Arm shaft ball bearing adaptor
23	10571	1	Screw for 13074
24	10568	1	Ball bearing retaining washer
25	10579	1	Balance wheel set screw (B)
26	10576	1	Balance wheel set screw (A)
27	15665	1	Balance wheel
28	10521	1	Needle bar crank position screw
29	10524	1	Screw for 10523 (A)
30	10764	1	Screw for 10523 (B)
31	10522	1	Needle bar crank set screw
32	10520	1	Needle bar crank
33	15033	1	Oiling wick for arm shaft
34	10506	1	Arm shaft oil packing stop screw
35	15011	1	Arm shaft
36	10566	1	Screw for 13075
37	13075	1	Arm shaft ball bearing adaptor sleeve
38	10567	1	Arm shaft ball bearing
39	1-577	1	Balance wheel adjusting screw
40	10882	1	Needle bar
41	11204	1	Needle blamp 1/4"
42	10535	1	Needle set screw
43	11194	2	Needle (DP x 7)
44	10563	1	Washer for 10562
45	11154	1	Lifting lever spring set screw
46	10524	1	Screw for 10562
47	10562	1	Arm shaft bushing (front)
48	10729	1	Oiling wick for 10562
49	10725	2	Felt for 10562 (small)
50	10621	1	Arm shaft timing belt
51	10524	1	Screw for 10570
52	10570	1	Arm shaft connecting belt pulley position screw
53	10569	1	Arm shaft connecting belt pulley
54	10571	1	Screw for 10569
55	10574	3	Arm shaft connecting belt pulley spring flange

### PRESSER BAR

Fig.No.	Parts No.	Qty.	Name
1	10761	1	Screw for 10543
2	10543	1	Presser bar position guide
3	16258	1	Presser bar bushing (upper)
4	10761	2	Screw for 16258 & 105339
5	10532	1	Screw for 10541
6	10541	1	Presser bar position guide bracket
7	10858	1	Lock washer for 10857
8	10857	1	Presser bar lifting bracket
9	10660	1	Presser bar lifting hinge screw
10	10659	1	Presser bar lifter
11	10532	1	Screw for 10549
12	10549	1	Presser bar spring bracket
13	10539	1	Presser bar bushing (lower)
14	10540	1	Presser bar
15	10664	1	Presser foot screw
16		1	Presser foot
17	10548	1	Presser bar lifting bracket guide screw
18	10712	2	Screw for 10710 & 10711
19	10710	1	Knee lifter lifting lever
20	10711	1	Knee lifter connecting lever
21	13059	1	Knee lifter lifting lever spring
22	11156	1	Presser bar spring regulating screw
23	10706	1	Presser bar spring support screw
24	10705	1	Presser bar spring (flat)
25	15076	1	Set pin for 15075
26	15075	1	Knee lifter connecting lever lifting rod
27	10561	1	Screw for 10714
28	10714	1	Lifting rod spring collar

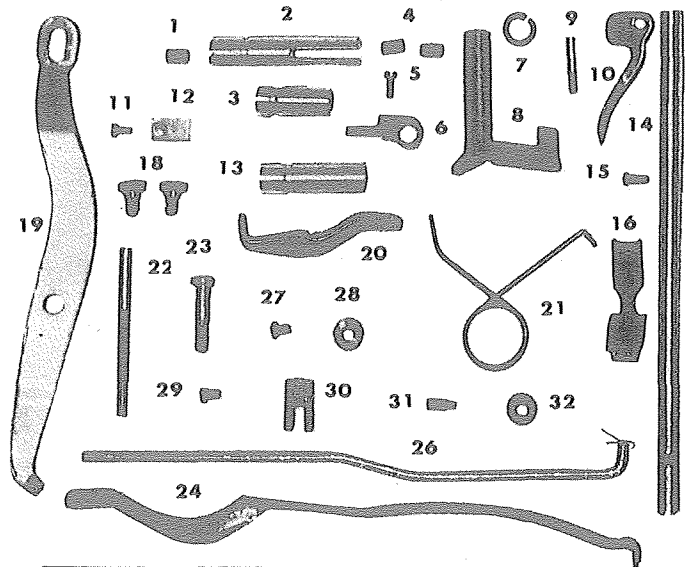

Fig.No.	Parts No.	Qty.	Name
29	10561	1	Screw for 10717
30	10717	1	Lifting rod roller bracket
31	10719	1	Lifting rod roller hinged screw
32	10718	1	Lifting rod roller

### THREAD GUIDE, TENSION BRACKET, OIL WICK FOR 332 & 332R OLD STYLE

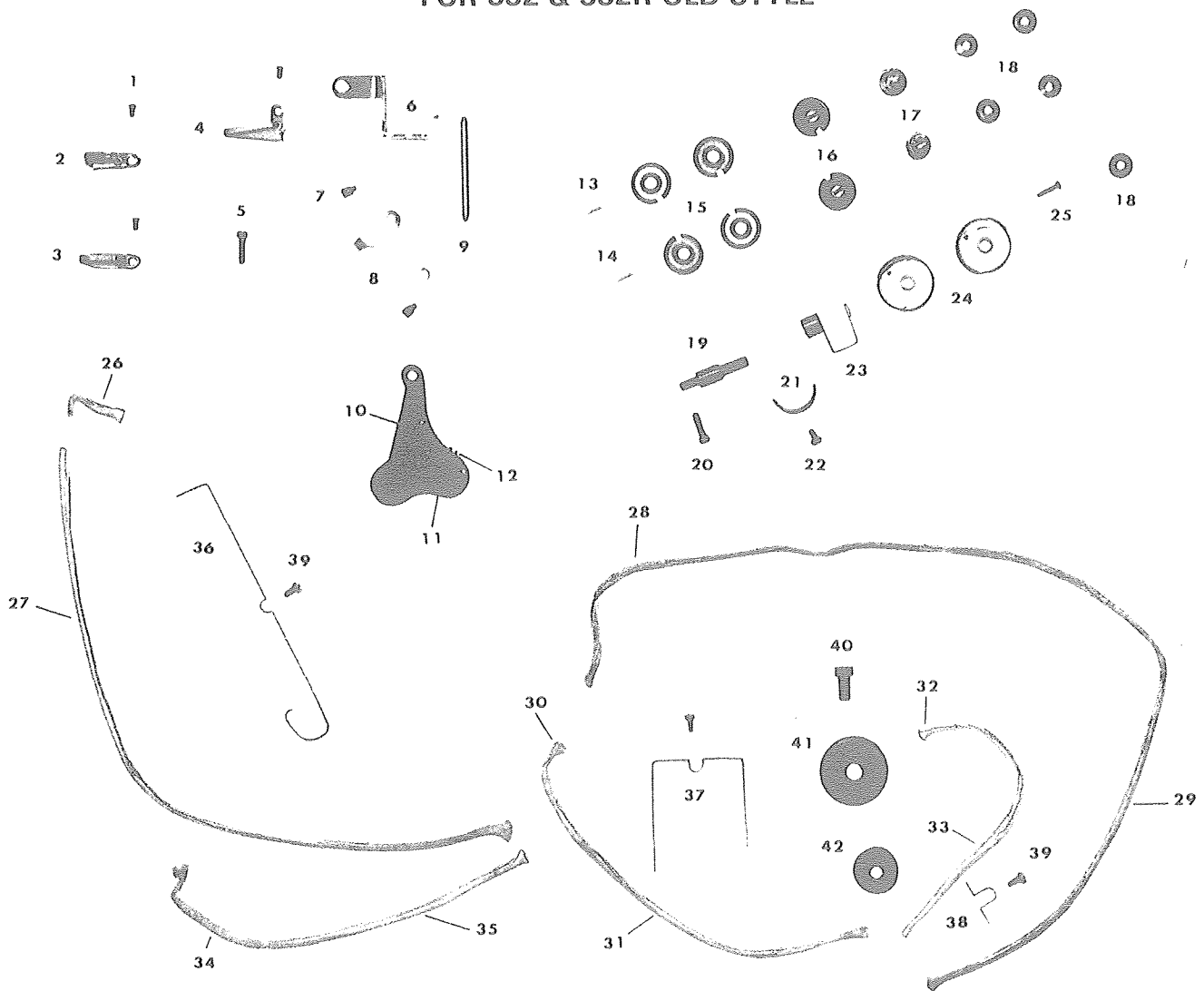

Fig.No.	Parts No.	Qty.	Name
1	10685	3	Thread guide set screw
2	10682	1	Thread guard (upper)
3	11160	1	Thread guard (middle)
4	10684	1	Thread guard (lower)
5	10545	1	Tension bracket set screw
6	15517	1	Thread retainer
7	10679	2	Tension release lever hinge screw
8	10678	1	Tension release lever
9	10720	1	Tension release lever rod
11	10791	2	Tension bracket pin
12	10789	2	Tension stud
13	10790	1	Tension release plunger (short)
14	10952	1	Tension release plunger (long)
15	10691	4	Thread disc
16	10692	2	Tension release washer
17	12048	2	Tension release spring
18	10697	5	Tension thumb nut
19	10951	1	Tension stud
20	8060	1	Screw for 10951
21	10690	1	Thread controller spring stop
22	10650	1	Screw for 10690

Fig.No.	Parts No.	Qty.	Name
23	10953	1	Thread controller spring
24	10694	2	Thread controller disc
25	10954	1	Screw for 10694
26	15514	1	Oiling wick No.4
27	15511	1	Vinyl pipe No.4
28	15069	1	Oiling wick No.1
29	15063	1	Vinyl pipe No.1
30	15071	1	Oiling wick No.3
31	15065	1	Vinyl pipe No.3
32	15070	1	Oiling wick No.2
33	15064	1	Vinyl pipe No.2
34	15515	1	Oiling wick No.5
35	15512	1	Vinyl pipe No.5
36	15508	1	Vinyl pipe guard(C)
37	15084	1	Vinyl pipe guard(B)
38	15083	1	Vinyl pipe guard(A)
39	6333	3	Screw for 15508, 15084 & 15083
40	11108	1	Screw for 11105
41	11105	1	Oil reservoir
42	11106	1	Felt for 11105

### HOOK DRIVING SHAFT

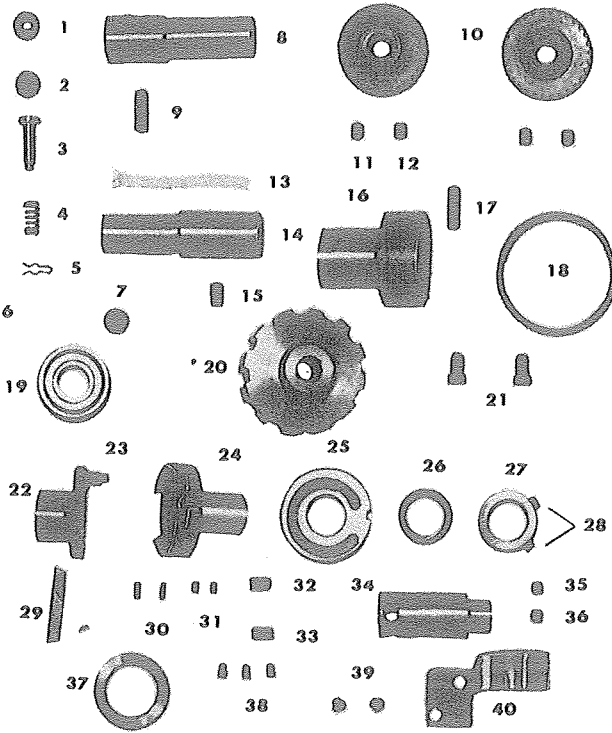
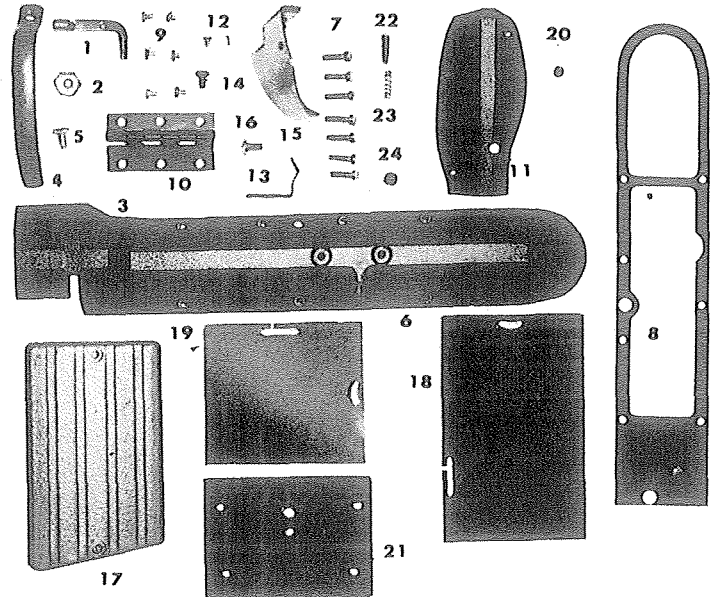

Fig.No.	Parts No.	Qty.	Name
6	12134	1	Hook driving shaft
7	11080	1	Felt for 10950
8	10950	1	Hook driving shaft bushing (front)
9	10571	1	Screw for 10950
10	15610	2	Hook driving gear (spiral)
11	10658	2	Screw for 15610 (A)
12	10767	2	Screw for 15610 (B)
13	10729	1	Oil wick for 10605
14	10605	1	Hook driving shaft bushing
15	10522	1	Screw for 10605
16	10606	1	Hook driving shaft ball bearing adaptor
17	10571	1	Screw for 10606
18	10574	1	Arm shaft connecting belt pulley spring flange
19	10567	1	Hook driving shaft ball bearing
20	10941	1	Hook driving shaft connecting belt pulley
21	10612	2	Screw for 10941
22	10632	1	Feed driving eccentric
23	10634	1	Feed driving eccentric pin
24	10627	1	Feed driving flange
25	10626	1	Feed driving eccentric adjusting disc
26	10625	1	Feed driving eccentric adjusting disc spring
27	10623	1	Collar for 10625
28	10566	2	Screw for 10623
29	10631	1	Feed driving eccentric friction gib
30	10629	2	Screw for 10631
31	10630	2	Position screw for 10631
32	10628	1	Screw for 10627
33	10765	1	Screw for 10627 (B) (A)
34	10607	1	Lower shaft ball bearing collar
35	10658	1	Screw for 10607 (A)
36	10566	1	Screw for 10607 (B)
37	10608	1	Lower shaft ball bearing retainer washer
38	10609	3	Screw for 10608
39	10597	2	Screw for 10822
40	10822	1	Arm shaft connecting belt timing plate

Fig.No.	Parts No.	Qty.	Name
1	11085	1	Hook driving shaft oil stop screw
2	11069	2	Felt for 10605
3	10671	1	Feed regulating stud (large)
4	10673	1	Feed regulating stud spring
5	10674	1	Feed regulating stud spring clip

### COVER PLATE, BED SLIDE

1	11006	2	Top arm thread guide
2	13076	2	Nut for 11006
3	15003	1	Arm top cover
4	11009	1	Take up lever cover
5	6031	1	Screw for 11009
6	11007	1	Oil level indicator
7	6604	7	Screw for 15003
8	15004	1	Gasket for arm top cover
9	8111	6	Screw for 15036
10	15036	1	Face plate hinge connection
11	15035	1	Face plate
12	8111	2	Screw for 15037
13	15037	1	Face plate spring
14	10650	1	Screw for 10551
15	10551	1	Needle bar connecting link oil guard
16	8040	2	Screw for 15006
17	15006	1	Arm side over
18	10040	1	Bed slide 1/16" to 3/32" (Front)
	10041	1	Bed slide 1/8"
	10042	1	Bed slide 3/16" to 1/4"
	10043	1	Bed slide 5/16"
	10044	1	Bed slide 3/8"
	10045	1	Bed slide 7/16" to 1/2"
	10046	1	Bed slide 5/8"
	10047	1	Bed slide 3/4"
	10048	1	Bed slide 7/16"
	10049	1	Bed slide 1"
	10050	1	Bed slide 1 1/4"
	10051	1	Bed slide 1 1/2"
19	10060	1	Bed slide (back) 1/16" to 3/16"
	10061	1	Bed slide 7/32" to 3/8"
	10062	1	Bed slide 7/16" to 1/2"



	10063	1	Bed slide 5/8" to 3/4"
	10064	1	Bed slide 7/8" to 1"
	10065	1	Bed slide 1 1/4" to 1 1/2"
20	13085	1	Screw for 11166
21	11166	1	Slide plate
22	10667	1	Slide plate (back) stop
23	10668	1	Slide plate (back) stop spring
24	15038	1	Face plate rubber

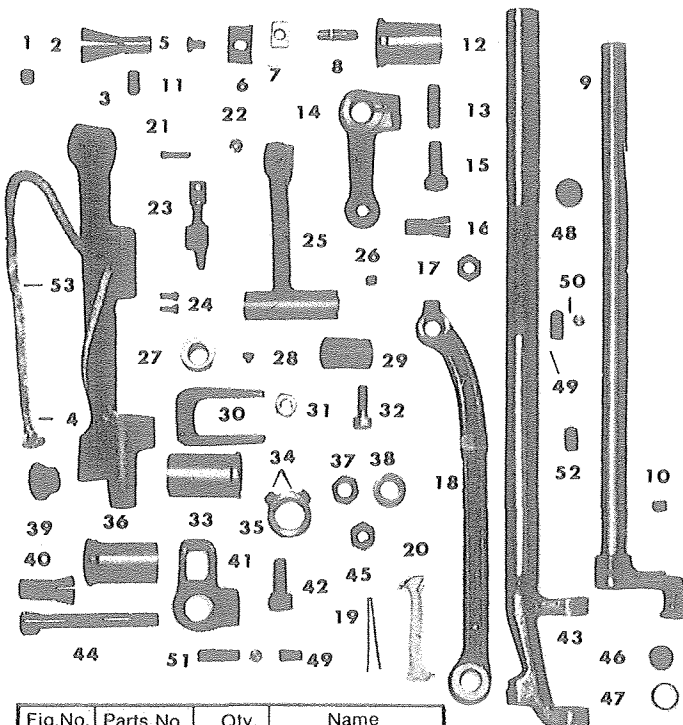

### FEEDER NEEDLE BAR FRAME

13	10571	1	Screw for 15015 (rear)
14	15016	1	Needle bar rock frame rock shaft crank
15	10519	1	Screw for 15016
16	8014	1	Hinge screw for 15016 (small)
17	8105	1	Nut for 8014
18	10756	1	Needle bar rock frame rock shaft crank connection
19	10779	1	Pin
20	10778	1	Oiling wick for 10756
21	11066	1	Feed dog support screw
22	11067	1	Nut for 11066
23		1	Feeder
24	10601	2	Feed dog screw
25	11065	1	Feed bar
26	10658	1	Screw for 10637
27	10637	1	Feed lifting cam
28	10597	1	Screw for 10596
29	10596	1	Felt for 10595
30	10595	1	Feed lifting cam fork
31	10599	1	Washer for 10598
32	10598	1	Feed lifter cam fork screw
33	10588	1	Feed driving rock shaft bushing (front)
34	10764	4	Screw for 10593
35	10593	2	Feed driving rock shaft stop collar
36	10763	1	Feed driving rock shaft bushing (rear)
37	3036	1	Nut for 10758
38	15018	1	Washer for 15017
39	15017	1	Needle bar rock frame regulating pipe
40	10758	1	Hinge screw for 10756
41	15019	1	Feed driving rock shaft bell crank
42	10754	1	Screw for 15019
43	10587	1	Feed driving rock shaft
44	10602	1	Feed bar screw stud
45	10636	1	Nut for 10602
46	11069	4	Felt for 10588 & 10763
47	11071	2	Packing for 11070
48	11070	2	Oil stop screw for 10588 & 10763
49	10522	2	Screw for 10588 & 10763
50	11068	2	Liner for 10588 & 10763
51	10571	1	Screw for 10763
52	10761	1	Screw for 10588
53	4221	1	Oiling wick guard

Fig.No.	Parts No.	Qty.	Name
1	10524	1	Screw for 10537
2	10537	1	Needle bar rock frame hinged stud
3	15304	1	Needle bar rock frame
4	15031	1	Oiling wick for 15304
5	10561	1	Screw for 10560
6	10560	1	Needle bar rock frame position bracket
7	10582	1	Needle bar rock frame slide block
8	10580	1	Needle bar rock frame slide block stud
9	10578	1	Needle bar rock frame rock shaft
10	10581	1	Screw for 10580
11	10524	1	Screw for 15015
12	15015	2	Needle bar rock frame rock shaft bushing

### REVERSE FEEDING — OLD STYLE

Fig.No.	Parts No.	Qty.	Name
1	10519	2	Screw for 10820
2	10820	1	Feed rock shaft bell crank
3	10821	1	Pin for 10820
4	10828	2	Screw for 10821
5	10829	1	Pin for 10818
6	10818	1	Felt for 10840
7	10840	1	Feed reverse fork
8	10819	1	Feed reverse fork collar
9	3036	2	Nut for 10758
10	10758	2	Hinge screw for 10839
11	10839	1	Feed reverse fork connecting link
12	10837	1	Felt for 10839
13	10828	1	Screw for 10838 (B)
14	10827	1	Screw for 10839 (A)
15	10838	1	Feed reverse shaft bell crank
16	10403	1	Feed reverse shaft
17	10811	1	Feed reverse shaft stop
18	10612	1	Screw for 10811
19	10813	2	Nut for 10812
20	10812	2	Feed reverse shaft stop regulating screw
21	10806	1	Reverse lever return spring
22	15208	1	Fulcrum shaft
23	10842	1	Fulcrum shaft bell crank
24	8007	1	Position screw for 10843
25	10812	1	Clamp screw for 10842
26	10841	1	Bell crank connecting rod
27	10712	2	Screw for 10841
28	10802	1	Fulcrum shaft collar
29	8009	1	Screw for 10802

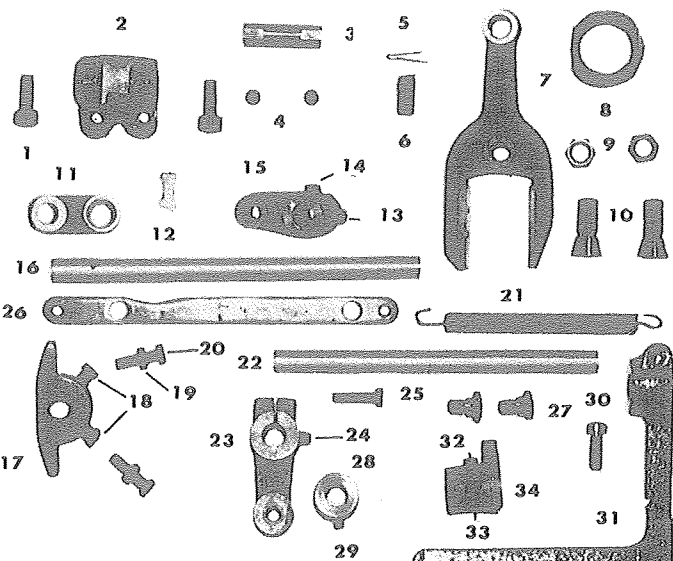

Fig.No.	Parts No.	Qty.	Name
30	1365	1	Screw for 10844
31	10844	1	Reverse feed lever
32	10828	1	Screw for 10843 (B)
33	10827	1	Screw for 10843 (A)
34	10843	1	Feed reverse shaft bell crank

### HOOK SADDLE

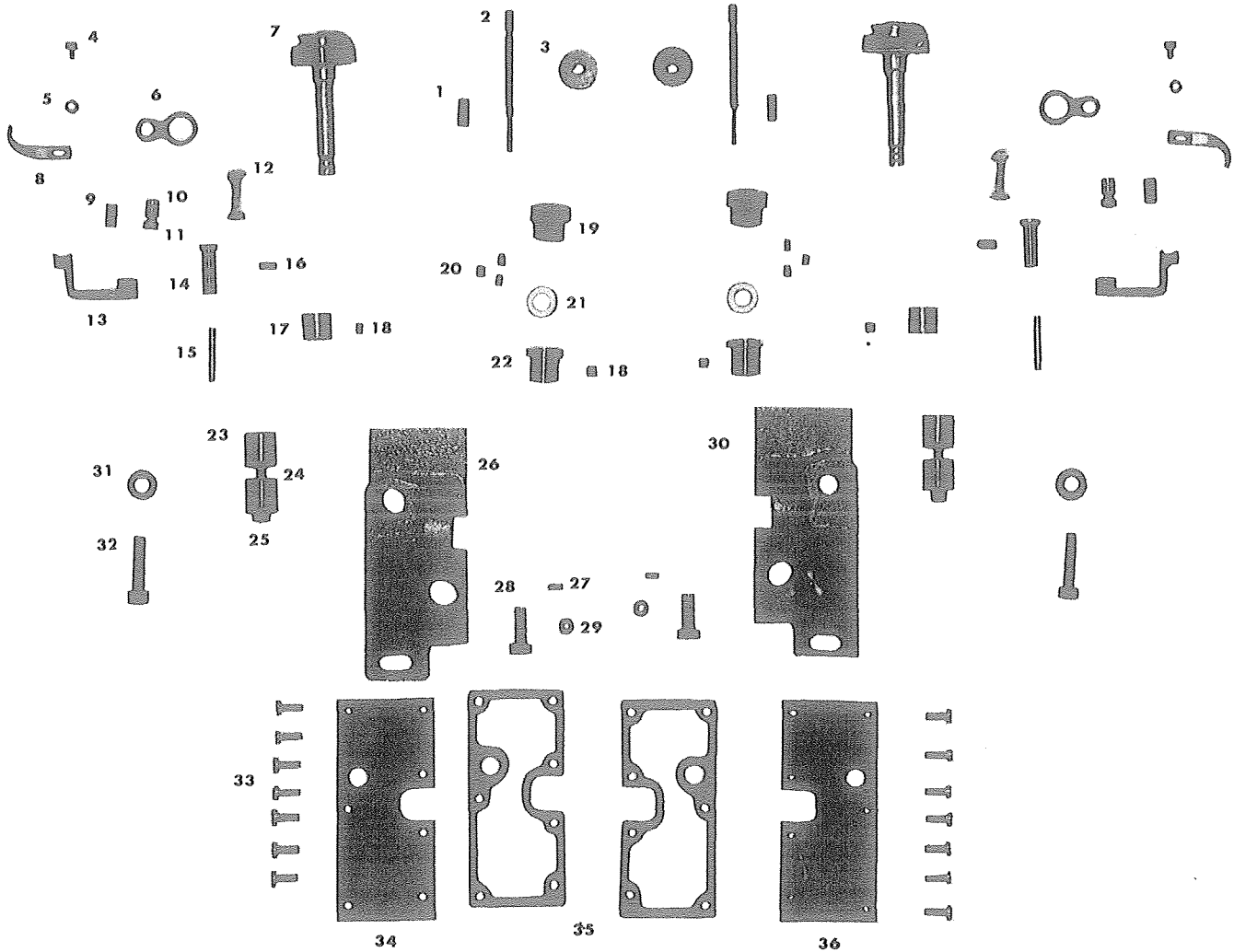
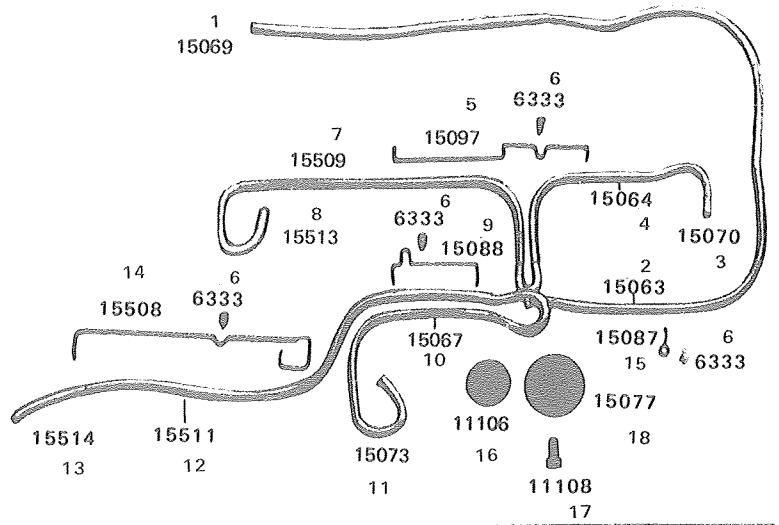

Fig.No.	Parts No.	Qty.	Name
1	11131	2	Oil indicator guide pipe
2	15052	2	Oil indicator
3	10656	2	Bobbin
4	10650	2	Bobbin case opener washer
6	19653	2	Bobbin case opener lever link
7	11124	2	Rotating hook complete
8	10649	2	Bobbin case opener
9	10717	2	Felt for 10651
10	10651	2	Bobbin case opener lever driving screw
11	10652	2	Nut for 10651
12	10727	2	Felt for 15609
13	10648	2	Bobbin case opener lever
14	15609	2	Bobbin case opener lever hinge pin
15	11137	2	Pipe for 15609
16	10573	2	Screw for 15609
17	15607	2	Hook bushing (upper)
18	11176	4	Screw for 15607 & 15608
19	11134	2	Hook driving pinion

Fig.No.	Parts No.	Qty.	Name
20	10767	6	Hook driving pinion set screw
21	10644	2	Washer for 15608
22	15608	2	Hook driving (lower)
23	11145	2	Hook saddle pinch collar(A)
24	11146	2	Hook saddle pinch collar (B)
25	11144	2	Hook saddle pinch screw
26	15606	1	Hook saddle (left)
27	10629	2	Screw for 15093
28	15093	2	Oil regulator dial
29	15094	2	Ring
30	15605	1	Hook saddle (right)
31	10647	2	Washer for 10646
32	10646	2	Hook saddle set screw
33	6604	14	Screw for 15521 & 15091
34	15521	1	Hook saddle oil reservoir (left)
35	15092	2	Gasket for hook saddle
36	15091	1	Hook saddle oil reservoir (right)

### NEW STYLE OIL WICK FOR BED

Fig. No.	Parts No.	Qty	Name
1	15069		Oiling wick - #1
2	15063		Vinyl pipe - #1
3	15070		Oiling wick - #2
4	15064		Vinyl pipe - #2
5	15097		Vinyl pipe stop
6	6333		Screw for 15097-15088-15508-15087
7	15509		Vinyl pipe - #3
8	15513		Oiling wick - #3
9	15088		Vinyl pipe stop
10	15067		Vinyl pipe - #4
11	15073		Oiling wick - #4
12	15511		Vinyl pipe - #5
13	15514		Oiling wick - #5
14	15508		Vinyl pipe stop
15	15087		Vinyl pipe stop
16	11106		Felt
17	11108		Screw for 15077
18	15077		Bed oil clamp



### ACCESSORIES

Fig. No.	Parts No.	Qty	Name
1	10735	1	Knee Lifter Complete
2	6052	3	Nail
4	8125	1	Oiler
5	15082	1	Oil Bottle
6	15081	6	Screw for 15080
7	15080	1	Oil pan
8	11171	2	Bed hinge connection base
9	6052	4	Screw for 11171
10	11170	4	Bed hinge connection set screw
11	11169	2	Bed hinge connection
12	15101	1	Bobbin winder complete
13	11197	1	Cotton stand complete
14	15099	1	Belt Guard
15	11162	2	Screw for 15099
16	12418	1	Screw for 15098
17	10598	1	Belt guard
18	11142	1	Washer
19	10650	1	Screw for 15098

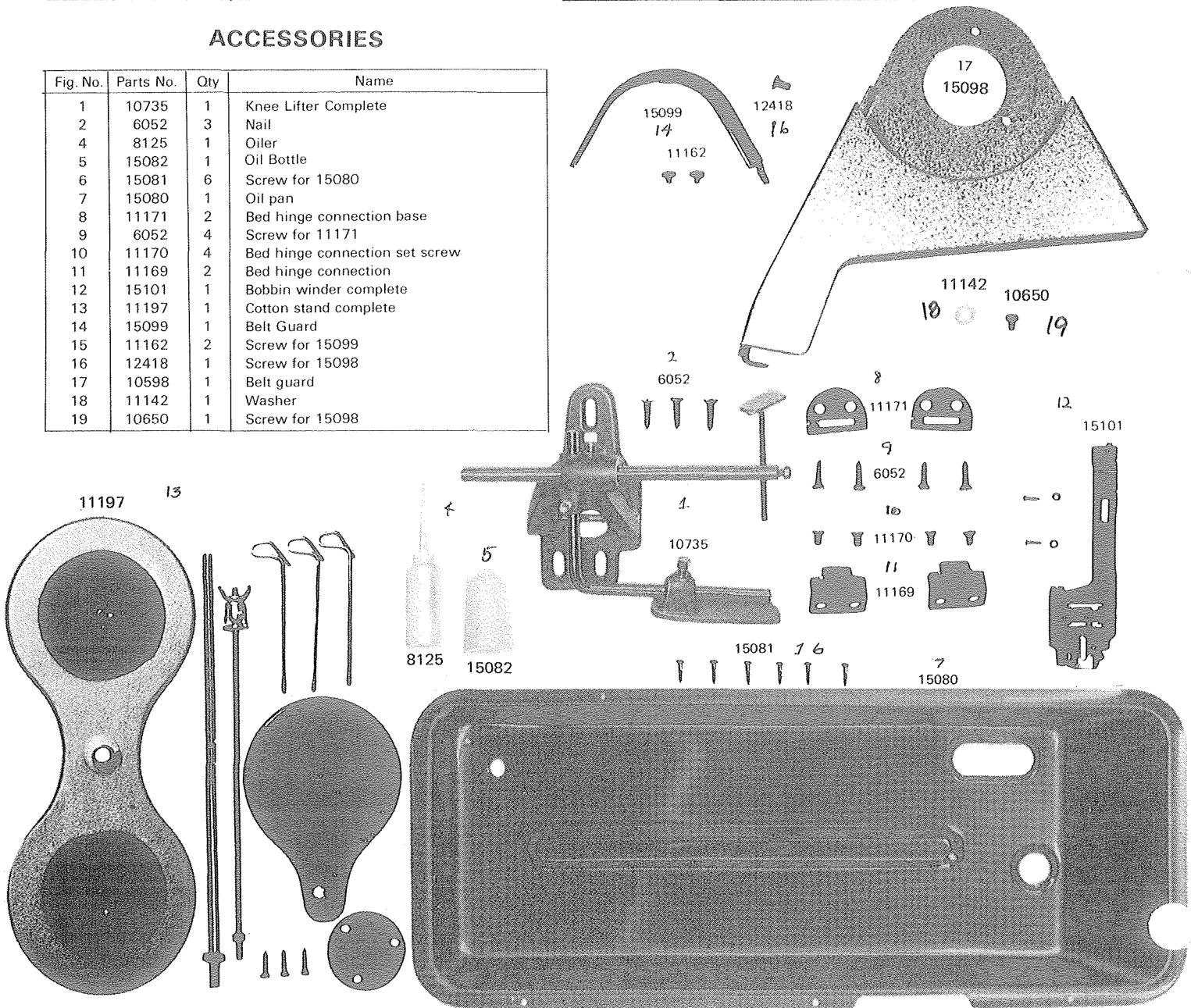

**NOTE: ALL LONG ARM MACHINES REQUIRE SPECIAL ORDER.**

**FOR DRIP PAN SHAFTS AND ALL OTHER EXTENDED PARTS PLEASE SPECIFY WHEN ORDERING.**

From the library of: Superior Sewing Machine & Supply, LLC

### NEW REVERSE STITCH MECHANISM FOR 332R-1 — ONLY

Fig. No.	Parts No.	Qty	Name
1	10754	2	Screw for 11961
2	11961	1	Feed rock shaft bell crank
3	11962	1	Pin for 11961
4	11954	1	Oiling wick for 11962
5	11953	2	Screw for 11962
6	11955	1	Feed reverse forked link
7	11956	1	Feed reverse connecting link
8	11953	3	Screw for 11952, 11959
9	11958	1	Change-over crank (left)
10	11950	1	Feed reverse pin
11	11959	1	Change-over crank pin
12	11960	1	Oiling wick for 11959
13	11957	1	Change-over crank (right)
14	10754	1	Screw for 11957
15	10404	1	Feed reverse shaft
16	11944	1	Feed reverse shaft bell crank
17	11945	1	Pin for 11944
18	11951	1	Connecting rod
19	11952	1	Connecting rod wrist pin
20	11954	1	Oiling wick for 11952
21	10773	1	Needle bearing for 11951
22	15023	1	Feed driving cam snap ring
23	11948	1	Feed reverse shaft stop
24	10754	1	Screw for 11948
25	11949	2	Screw for 11948
26	4135	2	Nut for 10949
27	11947	1	Fulcrum shaft collar
28	10566	2	Screw for 11947
29	10806	1	Reverse lever return spring
30	15208	1	Fulcrum shaft
31	11942	1	Fulcrum shaft bell crank
32	1365	1	Clamp screw for 11942
33	11943	1	Bell crank connecting rod
34	10712	2	Screw for 10943
35	10802	1	Fulcrum shaft collar
36	8009	2	Screw for 10802
37	10844	1	Reverse feed lever
38	10845	1	Screw for 10844
39	10634	1	Pin for 15022
40	15022	1	Feed Driving Eccentric

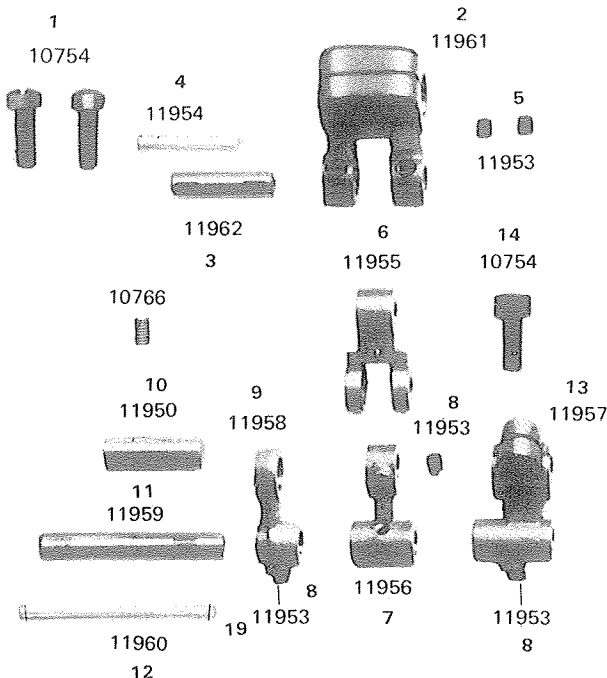
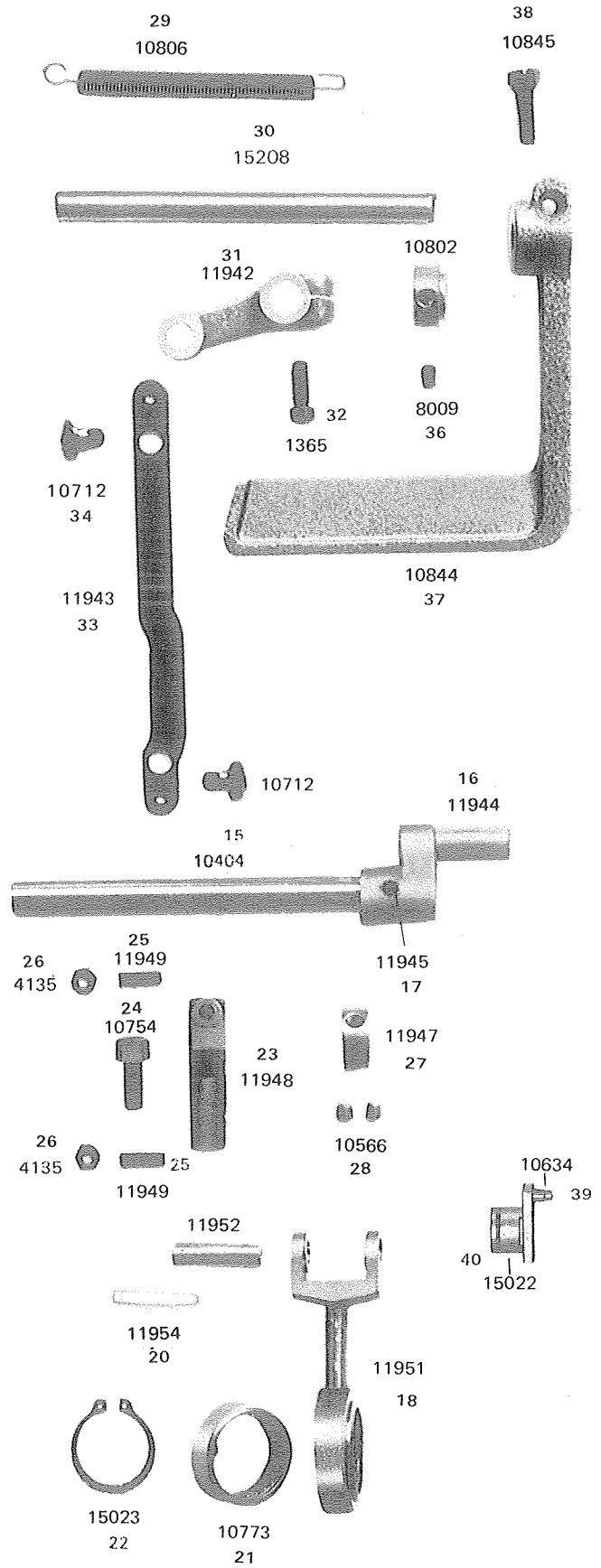

### GAUGE PARTS

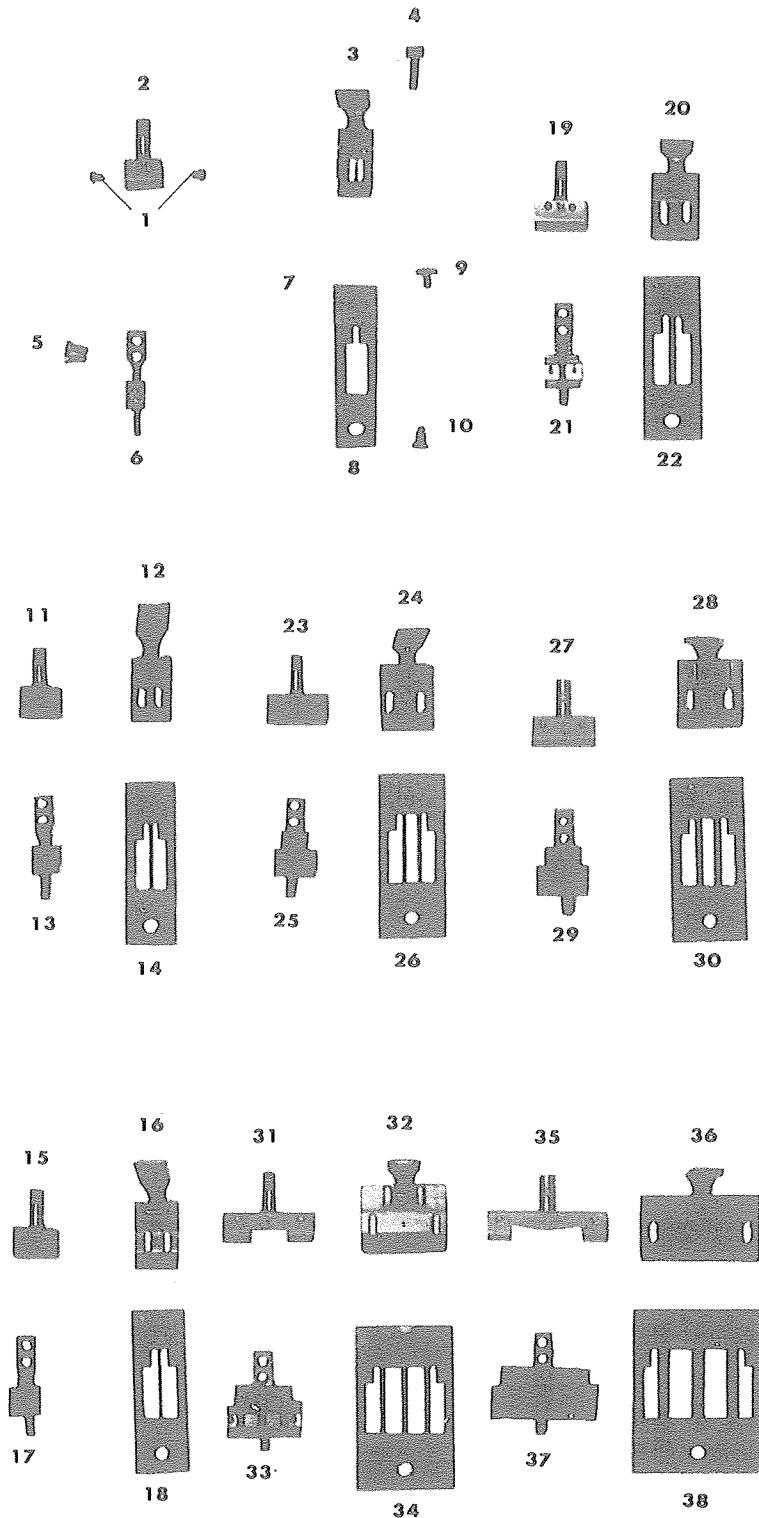

Fig.No.	Parts No.	Qty.	Name
1	10535	2	Needle set screw
2	11202	1	Needle clamp 1/8"
3	15632	1	Presser foot 1/8"
4	10864	1	Presser foot screw
5	10601	2	Feed dog screw
6	11232	1	Feed dog 1/8"
7	11163	1	Needle plate pin
8	11222	1	Needle plate 1/8"
9	11162	1	Needle plate position screw
10	6031	1	Needle plate screw
	11200	1	Needle clamp 1/16"
	15630	1	Presser foot 1/16"
	11230	1	Feed dog 1/16"
	11220	1	Needle plate 1/16"
	11201	1	Needle clamp 3/32"
	15631	1	Presser foot 3/32"
	11231	1	Feed dog 3/32"
	11221	1	Needle plate 3/32"
11	11203	1	Needle clamp 3/16"
12	15633	1	Presser foot 3/16"
13	11233	1	Feed dog 3/16"
14	11223	1	Needle plate 3/16"
	10024	1	Needle clamp 7/32"
	15634	1	Presser foot 7/32"
	10264	1	Feed dog 7/32"
	10224	1	Needle plate 7/32"
15	11204	1	Needle clamp 1/4"
16	15635	1	Presser foot 1/4"
17	11234	1	Feed dog 1/4"
18	11224	1	Needle plate 1/4"
	11205	1	Needle clamp 5/16"
	15636	1	Presser foot 5/16"
	11235	1	Feed dog 5/16"
	11225	1	Needle plate 5/16"
19	11206	1	Needle clamp 3/8"
20	15637	1	Presser foot 3/8"
21	11236	1	Feed dog 3/8"
22	11226	1	Needle plate 3/8"
	10028	1	Needle clamp 7/16"
	15638	1	Presser foot 7/16"
	10268	1	Feed dog 7/16"
	10228	1	Needle plate 7/16"
23	10029	1	Needle clamp 1/2"
24	15639	1	Presser foot 1/2"
25	10269	1	Feed dog 1/2"
26	10229	1	Needle plate 1/2"
	10030	1	Needle clamp 9/16"
	15640	1	Presser foot 9/16"
	10270	1	Feed dog 9/16"
	10230	1	Needle plate 9/16"
27	10031	1	Needle clamp 5/8"
28	15641	1	Presser foot 5/8"
29	10271	1	Feed dog 5/8"
30	10231	1	Needle plate 5/8"
	10032	1	Needle clamp 3/4"
	15642	1	Presser foot 3/4"
	10272	1	Feed dog 3/4"
	10232	1	Needle plate 3/4"
	10033	1	Needle clamp 7/8"
	15643	1	Presser foot 7/8"
	10273	1	Feed dog 7/8"
	10233	1	Needle plate 7/8"
31	10034	1	Needle clamp 1"
32	15644	1	Presser foot 1"
33	10274	1	Feed dog 1"
34	10234	1	Needle plate 1"
	10035	1	Needle clamp 1 1/4"
	15645	1	Presser foot 1 1/4"
	10275	1	Feed dog 1 1/4"
	10235	1	Needle plate 1 1/4"
35	10036	1	Needle clamp 1 1/2"
36	15646	1	Presser foot 1 1/2"
37	10276	1	Feed dog 1 1/2"
38	10236	1	Needle plate 1 1/2"